

Features the exclusive  
rotating boom

- Capacity on Outriggers ... 2,270 kg
- Pick and Carry Capacity ... up to 2,270 kg
- Height ... 1.67 m w/o Operator Guard
- Height ... 2.29 m with Operator Guard
- Width ... 1.22 m
- Boom Rotation ... 90 Degrees
- Sheave Height ... up to 8.4 m
- Horizontal Reach ... up to 6.7 m
- Tight Turning Radius
- Rear Wheel Steer ... Standard
- Front Wheel Drive ... Standard
- Fully Hydraulic Controls for Smooth Precise Operations
- Dual Fuel or Diesel Available

**BRODERSON**  
Manufacturing Corp.



# IC-20-H

LOAD RADIUS METERS	3-SECTION BOOM				2.1M JIB ON RUBBER OR OUTRIGGERS
	FRONT ON RUBBER	FRONT ON OUTRIGGERS	LEFT SIDE ON RUBBER	LEFT SIDE ON OUTRIGGERS	
1.2	1130	2270	1720	2270	590
1.5	920	1840	1430	1840	510
2.0	670	1370	990	1370	310
2.5	630	1110	650	1110	290
3.0	590	920	460	920	250
3.5	550	770	370	700	230
4.0	520	660	290	530	220
4.5	500	550	230	460	220
5.0					200
5.5					170
6.0					130
6.7					100

CAPACITIES ON OUTRIGGERS ARE 85% OF TIPPING LOADS. CAPACITIES ON RUBBER ARE 75% OF TIPPING LOADS.

CAPACITIES BELOW BOLD LINE ARE LIMITED BY TIPPING. OTHER CAPACITIES ARE LIMITED BY STRUCTURAL OR HYDRAULIC CAPACITY.

BOOM ANGLE MUST NOT BE LESS THAN 30° EXCEPT WHILE RIGGING IF THE JIB IS IN THE 30° OFFSET POSITION.

JIB DEDUCT: 68 KGS. IN WORKING POSITION WITH LOAD ON MAIN BOOM. ENSURE ANTI-TWO BLOCK SWITCH ON THE MAIN BOOM IS FUNCTIONING.

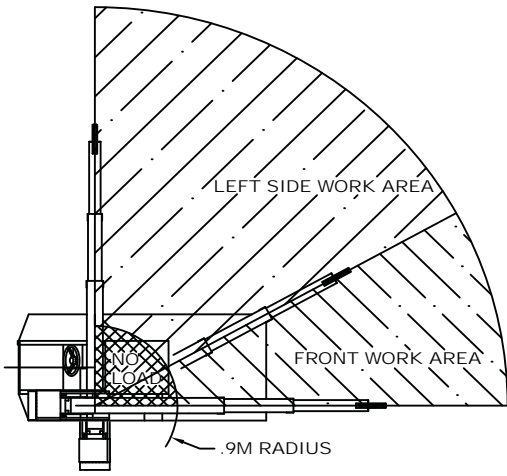
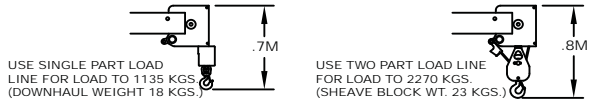

WORK AREA DIAGRAM

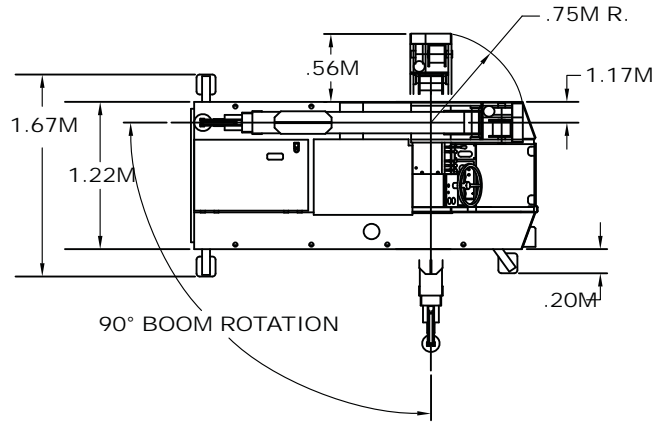
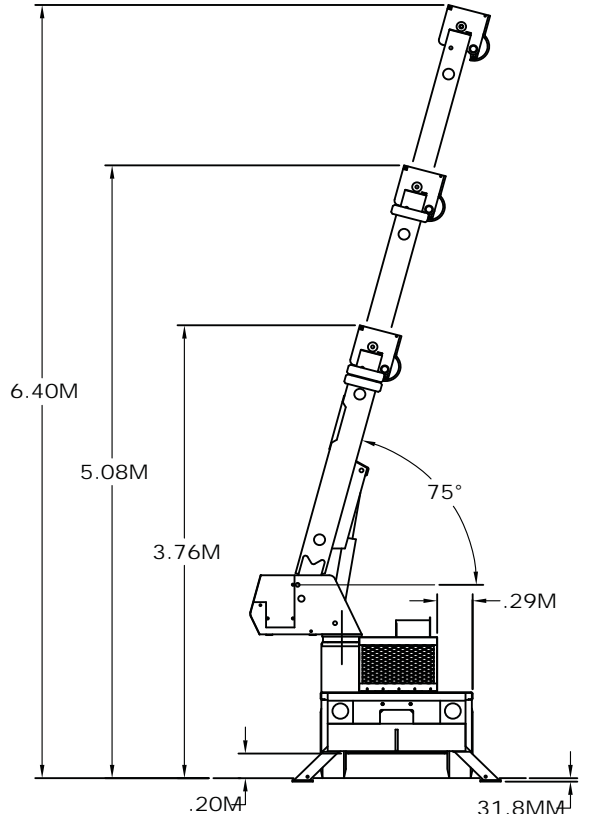
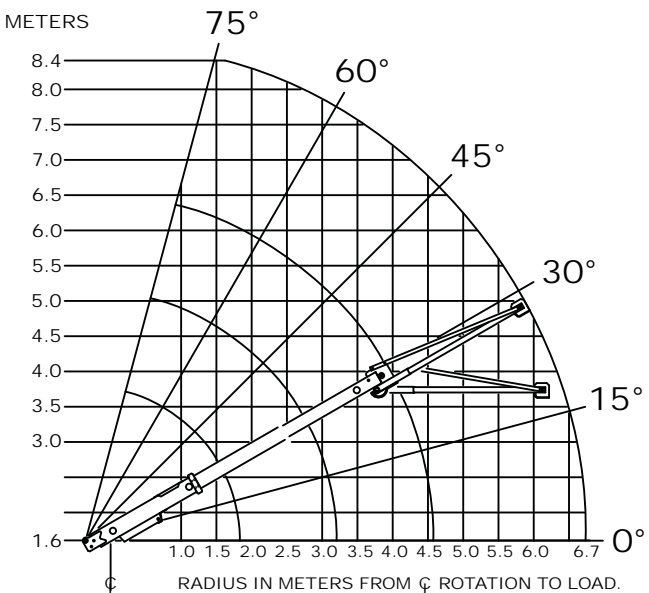

90° BOOM ROTATION

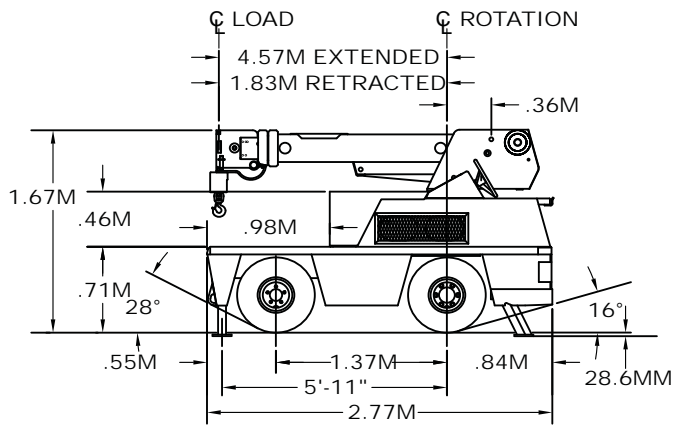

# IC-20-H

## Specifications

### GENERAL:

<b>Weight</b>	2,890 m
<b>Travel Speed</b>	0 to 8.9 km/h
<b>Drawbar Pull</b>	1,360 kg
<b>Boom Movement:</b>	
Rotation	90°
Elevation	0° to 75°
Extension	1.83 m to 4.57 m
<b>Boom Speeds:</b>	
Rotation	10 seconds
Elevation	9 seconds
Extension	25 seconds

### ENGINE:

Make	GM	Cummins
Model	2.4 L EFI	A2300
Type	Dual Fuel	Diesel
No. Cyl.	4	4
Displacement	2.4 L	2.3L
HP @ Gov. Speed	48 kW	34 kW
EPA Certification	Tier 2	Tier 4 (interim)
Fuel Tank Capacity	51 L	

### HYDROSTATIC PUMP:

Piston type, direct driven from engine crankshaft. Maximum flow 114 l/m. Maximum pressure 207 bar.

### AXLES:

#### Front Axle:

Contains planetary geared torque hubs and high torque hydraulic drive motors. Axle oscillates a total of 3.81 cm.

#### Rear Axle:

Non-oscillating.

### STEERING:

Hydraulic steering unit controls cylinder attached to rear axle.

### BRAKES:

Primary braking from hydrostatic transmission. Foot-actuated disc brakes for additional braking. Spring applied hydraulic released park brake, actuated from a toggle switch on operator's control panel. All braking is on front wheels.

### TIRES:

Front - 7.5 x 10 pneumatic, 16-ply

Rear - 7.5 x 10 pneumatic, 16-ply

### CHASSIS:

#### CARGO DECK:

1.8 m<sup>2</sup> of deck area. 2,270 kg capacity.

#### OUTRIGGERS:

Three hydraulic outriggers of box-beam construction. Independent controls for each. Hydraulic cylinders are equipped with direct-connected holding valves.

#### Lifting Sling Brackets

Includes two lift rings in front deck and lug on turntable for attaching lifting sling cables. Cables not included.

#### Pulling Eye

Mounted on front bumper.

### OPERATOR COMPARTMENT:

Provides one-position access to all chassis & crane functions. Includes fire extinguisher & bubble level.

### ELECTRICAL:

#### 12 Volt System

#### Lighting Package:

One pair headlights and taillight.

#### Instrument Package:

Lighted fuel, ammeter, oil pressure, and water temperature gauges, hydraulic oil temperature gauge and hourmeter.

#### Back-Up Alarm:

Provides pulsating sound from 97dB alarm when transmission is in reverse.

#### Outrigger Alarm System:

Two-tone alarm is activated when "outrigger down" or "outrigger out" controls are operated.

### HYDRAULIC SYSTEM:

Tandem pump mounted to rear of hydrostatic piston pump. Delivers 23 l/m at 172 bar for boom circuits and 61 l/m at 172 bar for hoist circuit. System protected by relief valves. Hydraulic oil reservoir has 36 L capacity.

### BOOM ASSEMBLY:

Three-section boom assembly equipped with bearing pads, double-acting hydraulic cylinders extends boom. The primary extension cylinder and the double-acting boom elevation cylinder are equipped with direct connected holding valves. Boom angle indicator on left side of boom.

### Boom Rotation:

Two double-acting hydraulic cylinders connected to turntable torque tube provides 90° rotation. Heavy-duty ball bearing supports boom.

### Anti-Two-Block Device:

Prevents damage to hoist rope and/or crane components from pulling load hook against tip.

### Sheave Block, Two-Part:

Single sheave block for 2-part line requirements.

# IC-20-H

## Options

Listed below are brief descriptions of options available for this product.  
Consult the IC-20-1H Engineering Spec for additional information.

#### MODEL:

IC-20-1H Industrial Crane

#### ENGINE OPTIONS:

##### Spark Arrester Muffler

Installed in addition to std. muffler.

##### Engine Shut Down Gauges

Shuts engine off when high water temperature or low engine oil pressure occurs. For diesel only.

#### TIRE OPTIONS:

##### Solid Rubber Tires

For applications where hazardous ground conditions exist.

##### Solid Rubber Tires - Non Marking

##### Foam Filling of Tires

##### Spare Tire & Wheel, pneumatic

##### Spare Tire & Wheel, Solid Rubber

##### Spare Tire & Wheel, Solid Rubber - Non Marking

##### Foam Filling of Spare Tire

#### CARGO DECK OPTIONS:

##### Deck Mat

#### CHASSIS OPTIONS:

##### Auxiliary Winch

Mounted behind the front bumper, hydraulically driven with control in operator's console (1,360 kg @ 6.1 meter per minute).

##### Pintle Hook - Rear

Holland "T-60-A" pintle hook mounted on rear of frame. 4.5-tonne capacity.

##### Lifting Sling

Three leg lift sling to attach to Lifting Rings.

##### Rearview Mirrors

One mounted on right-hand deck stake and one mounted on left-hand deck stake.

#### OPERATOR COMPARTMENT OPTIONS:

##### Operator Guard

Tubular steel weldment with heavy expanded steel mesh top section. Overhead height with guard installed is 2.29 m.

##### Floor Mat

Vinyl mat with foam backing.

#### ELECTRICAL OPTIONS:

##### Strobe Lights

One yellow strobe light mounted on top of operator's guard for high visibility. When the operator's guard is not ordered the strobe light is mounted on left-hand frame rail.

##### Boom Work Lights

One work light mounted to boom to light boom tip and one work light mounted to turret to light ground under boom tip.

#### BOOM ATTACHMENTS:

##### Boom Swing Lock

Prevents boom from being swung in normal 90 degree arc.

##### 2.13 m Pin-On Jib

Consists of jib with pair of tension bars, tip sheave, cable keeper and jib attaching pins. Tension bars provide two positions: In-line and 30 degree offset.

##### Rated Capacity Limiter:

Warns operator of impending overload with audible and visual signals. Prevents overload by stopping boom functions that cause overloads. Readouts for load, boom angle, and load radius

Should you require an option or special equipment not listed please consult your dealer salesperson or BMC®.

## **BRODERSON**

Manufacturing Corp.

14741 West 106th Street

Lenexa, KS 66215 USA

Tel (913) 888-0606

Fax (913) 888-8431

www.bmccranes.com

Dimensions and values shown are

for reference purposes only.

Specifications subject to change.

